

No.	DESCRIPTION	MATERIAL
1	SPUD	CAST LOW LEAD BRASS ALLOY
2	COMP GSKT	NITRILE ASTM D2000
3	WASHER	POLYPROPYLENE
4	CPLG NUT	CAST BRASS ASTM B62 ALLOY C83600

SIZE	A	B
1"	2.000	2.000
1-1/2"	2.969	2.969
2"	3.625	3.625

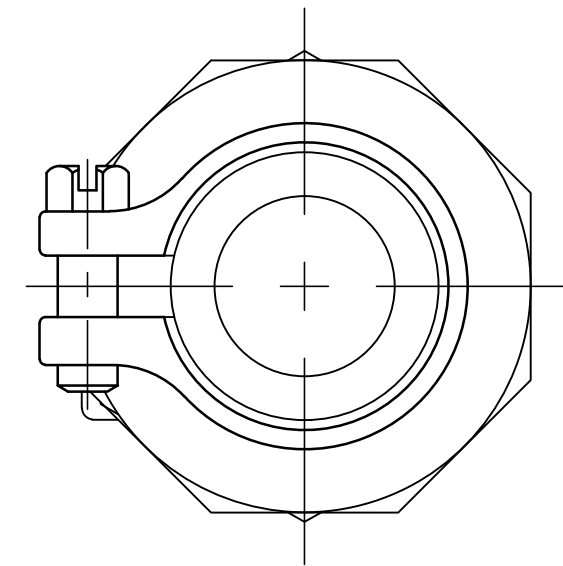
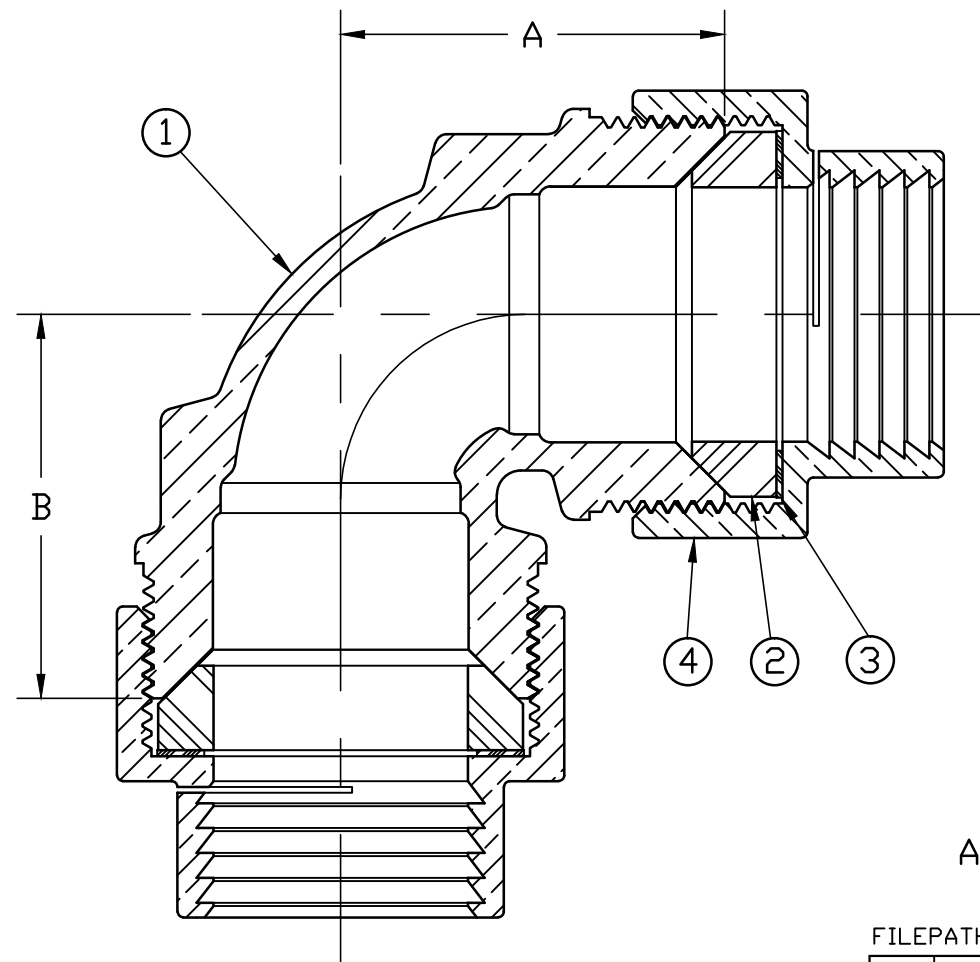

ALL WETTED PARTS ARE LOW LEAD BRASS ALLOY

FILEPATH: PROD-ENG\JAMESJONES\ASYSUBMITTALS\E2626

						DRFTR	RWB	4/26/16	JONES	THIRD ANGLE PROJECTION 	
						CHKR					
						ENGR					
						MGR					
									UNLESS OTHERWISE NOTED		
									SURFACE PREPARATION:		
									BREAK CORNER(S) ---- .000		
									SURFACE FINISH -- XX RMS	REF. No.	
									TOLERANCE(S):	SCALE	
									LINEAR ----- ± .000	NONE	
									ANGULAR ----- ± 0°00'		
						STK No:			MAT'L:		
						DESCR.	90° ELL LLB SERVICE FITTING (IPS PVC PJ x IPS PVC PJ)			DWG NUMBER	
										E2626	
						REV	ECR	DESCRIPTION	DATE	BY	CHKR
						PER EST NO: DXXXX EST FIN WT = 0.0000 lbs					

DWG NUMBER
E2626
JJ-MRKTNG

TITLE TO AND OWNERSHIP OF THIS ENGINEERING DATA REMAINS IN Mueller Co. NO USE IS TO BE MADE OF THIS DATA EXCEPT AS SPECIFICALLY AUTHORIZED BY Mueller Co. ASSENT ON THE PART OF THE RECIPIENT TO THESE CONDITIONS IS PRESUMED.