

No.	DESCRIPTION	MATERIAL
1	STEM	CAST LOW LEAD BRASS ALLOY
2	O-RING	EPDM ASTM D2000
3	BALL	CAST LOW LEAD BRASS ALLOY
4	GASKET - SEAL	NITRILE ASTM D2000
5	BODY	CAST LOW LEAD BRASS ALLOY
6	O-RING	EPDM ASTM D2000
7	END PIECE	CAST LOW LEAD BRASS ALLOY
8	CTS GSKT SUB	SBR ASTM D2000 -GSKT 410ss -BAND
9	CONNX NUT	CAST BRASS ASTM B62 ALLOY C83600

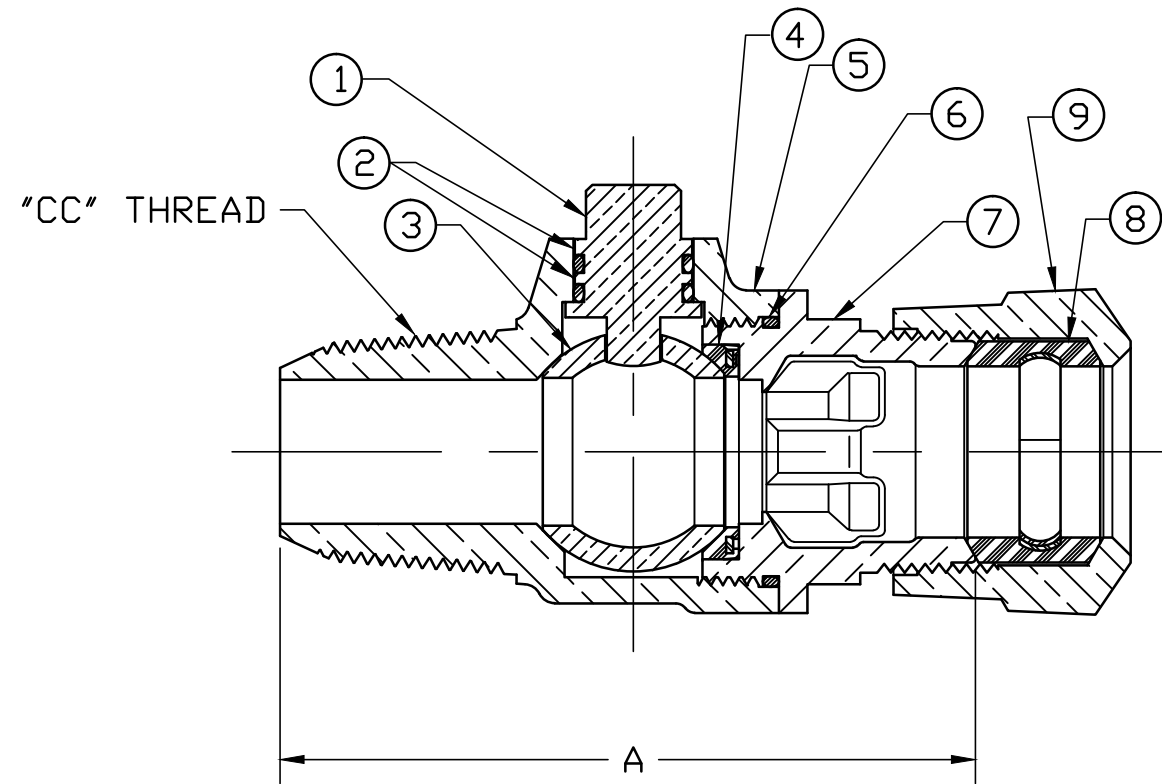

VALVE SIZE	A
3/4"	3-5/8"
1"	4-41/64"
1-1/2"	5-5/32"
1-1/2x2"	5-1/8"
2"	7-5/16"

ALL WETTED PARTS ARE LOW LEAD BRASS ALLOY

FILEPATH: PROD-ENG\JJ\SUBMITTALS\E1937SG

						DRFTR	RWB	6/9/08	JONES	UNLESS OTHERWISE NOTED THIRD ANGLE PROJECTION SURFACE PREPARATION: BREAK CORNER(S) ---- .000 SURFACE FINISH -- XX RMS TOLERANCE(S): LINEAR ----- ± .000 ANGULAR ----- ± 0°00'	REF. No.	SCALE
						CHKR						
						ENGR						
						MGR						
								BY	DATE			
								STK No:				
								MAT'L:				
								DESCR.	BALL TYPE LLB CORP VALVE (AWWA TAPER THR'D x 110 CTS)		DWG NUMBER E1937SG	
REV	ECR	DESCRIPTION	DATE	BY	CHKR							

TITLE TO AND OWNERSHIP OF THIS ENGINEERING DATA REMAINS IN Mueller Co. NO USE IS TO BE MADE OF THIS DATA EXCEPT AS SPECIFICALLY AUTHORIZED BY Mueller Co. ASSENT ON THE PART OF THE RECIPIENT TO THESE CONDITIONS IS PRESUMED

DWG NUMBER
E1937SG
JJ-MRKTNG