

# U.S. PIPE VALVE & HYDRANT, LLC

## U-20806/U-20807 SHALLOW BURY

### ADJUSTABLE VERTICAL INDICATOR POST

#### INSTALLATION INSTRUCTIONS

#### GENERAL DESCRIPTION

Vertical Indicator Posts (Ref. Figure A) are designed to operate non-rising stem (inside screw) gate valves, which are used to control an underground water supply to automatic sprinkler, water spray deluge, foam-water deluge, or standpipe fire protection systems. They permit operation of underground valves while providing an above ground visual indication as to whether the valves are open or shut, in addition to a means for locking the valves in a particular position. Indicator posts provide for valve operation from outside of the protected property and, therefore, the opportunity for more prompt valve operation in an emergency situation.

Model U-20806/U-20807 Indicator Posts feature a telescoping Stem that can be adjusted to its final position without field cutting of the Stem. The telescoping Stem also permits: easier setting of the "OPEN" and "SHUT" Target Plates (before the Post is extended to its final position); easier adjustment of the post length during the initial installation; and, ready re-adjustment of the post length, if there is a modification in the location of the final grade.

U-20806 Indicator Posts will accommodate 4 through 14 inch size post indicator valves (PIV) requiring 14 to 43 turns to open and that are listed or approved for fire protection system service. The U-20807 Post will accommodate 16-24 inch size post indicator valves requiring 49 to 75 turns to open.

Indicator Posts are provided "standard order" for use with left hand opening valves; however, they may be "special ordered" for use with right hand opening valves or converted in the field for use with a right hand opening valve by changing the left hand opening Post Head to a right hand opening Post Head.

Indicator Posts accept direct attachment of a 1/2 inch NPT mounting electric supervisory switching device which can be used by proprietary and central stations to monitor the open position of the Indicator Post. Detailed information on attaching a UL/FM approved Supervisory Control Valve Switch (supplied by customer) is given in the Technical Data section.

#### APPROVALS AND STANDARDS

Model U-20806/U-20807 Indicator Posts are listed by Underwriters Laboratories Inc. (UL). Model U-20806 Indicator Posts are approved by Factory Mutual Research Corporation.

Fig. A

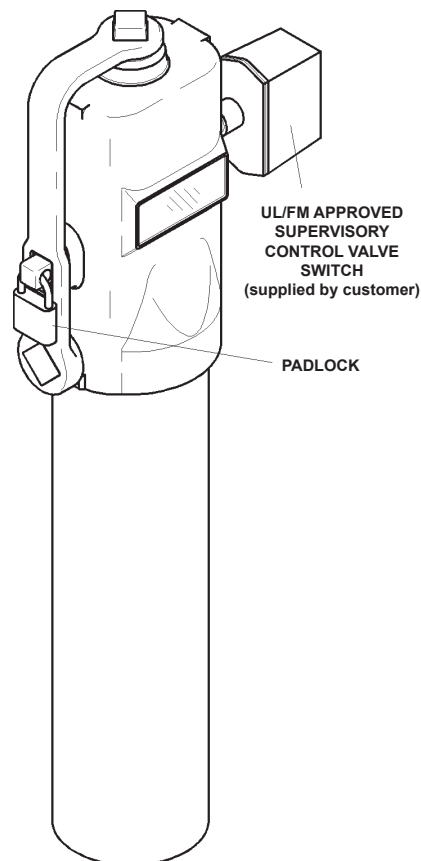

TYPICAL INSTALLATION OF:  
U-20806 - 4"-14" POST INDICATOR VALVES  
U-20807 - 16"-24" POST INDICATOR VALVES

#### ⚠ WARNING ⚠

***The Model U-20806/U-20807 Indicator Posts described herein must be installed and maintained in compliance with this document, as well as with the applicable standards of the National Fire Protection Association, in addition to the standards of any other authorities having jurisdiction. Failure to do so may impair the integrity of these devices.***

***The owner is responsible for maintaining their fire protection system and devices in proper operating condition. The installing contractor or manufacturer should be contacted relative to any questions.***

***Removing or disabling the tamper resistant feature of the special key wrench screw used to secure the cover of the Supervisory Control Valve Switch will void its listings and approval.***

# U.S. PIPE VALVE & HYDRANT, LLC U-20806/U-20807 SHALLOW BURY ADJUSTABLE VERTICAL INDICATOR POST

## INSTALLATION INSTRUCTIONS

### TECHNICAL DATA

#### Indicator Posts:

The U-20806/U-20807 Indicator Post bolts directly onto the stuffing box flange of 4 through 24 inch post indicator valves (PIV) employing 2 inch operating nuts. The Bell attaches to a PIV mounting flange having four bolt holes spaced at 90° on a 10-1/2 inch diameter bolt circle. The Bell has 3/4 inch clearance holes for the mounting bolts.

The U-20806 Indicator Post has a Threaded Sleeve which can readily accommodate field positioning of the "OPEN" and "SHUT" Targets for 4 through 14 inch PIVs requiring 14 to 43 turns to open. The U-20807 has a Threaded Sleeve for 16 through 24 inch PIVs requiring 49 to 75 turns to open.

The Shallow Bury U-20806/U-20807 Indicator Post provides for adjustment of dimension "D" in Figure B, as indicated in Table 3. The Post Head can be adjusted relative to the Lower Barrel by using the two Set Screws located at the base of the Upper Barrel. The Stem requires no field cutting within the indicated adjustment range of each "Order Length."

Tables 4a and 4b indicate the nominal trench depths which can be accommodated for 4 through 24 inch U.S. Pipe Valve & Hydrant, LLC Resilient Wedge PIVs based on the typical diameter of underground pipe.

"Standard order" Posts are factory set with the "OPEN" and "SHUT" Targets positioned for use with left hand (counter-clockwise) opening valves. An arrow on the Post Head indicates the left hand direction of opening. The position of the Targets may be reversed in the field, in order to accommodate a right hand opening valve, provided that the Post Head is changed to one indicating right hand opening.

The Post Head and Bell are ASTM A126 Class B gray iron. The Cap is polypropylene; Operating Nut and U-20806 Wrench are ASTM A536 (Grade 64-45-12) ductile iron. The Windows are made from plexiglass. The Lower Barrel is PVC DR14 (UL Listed). The Upper Barrel, Upper Stem, Lower Stem, Coupling, Coupling Insert, and U-20807 Wrench are carbon steel. The Targets for both posts are Nylon. The U-20806 Threaded Sleeve is Nylon; the U-20807 Threaded Sleeve is Aluminum. The Post Head, Upper Barrel, and Wrench are painted red.

**Fig. B**

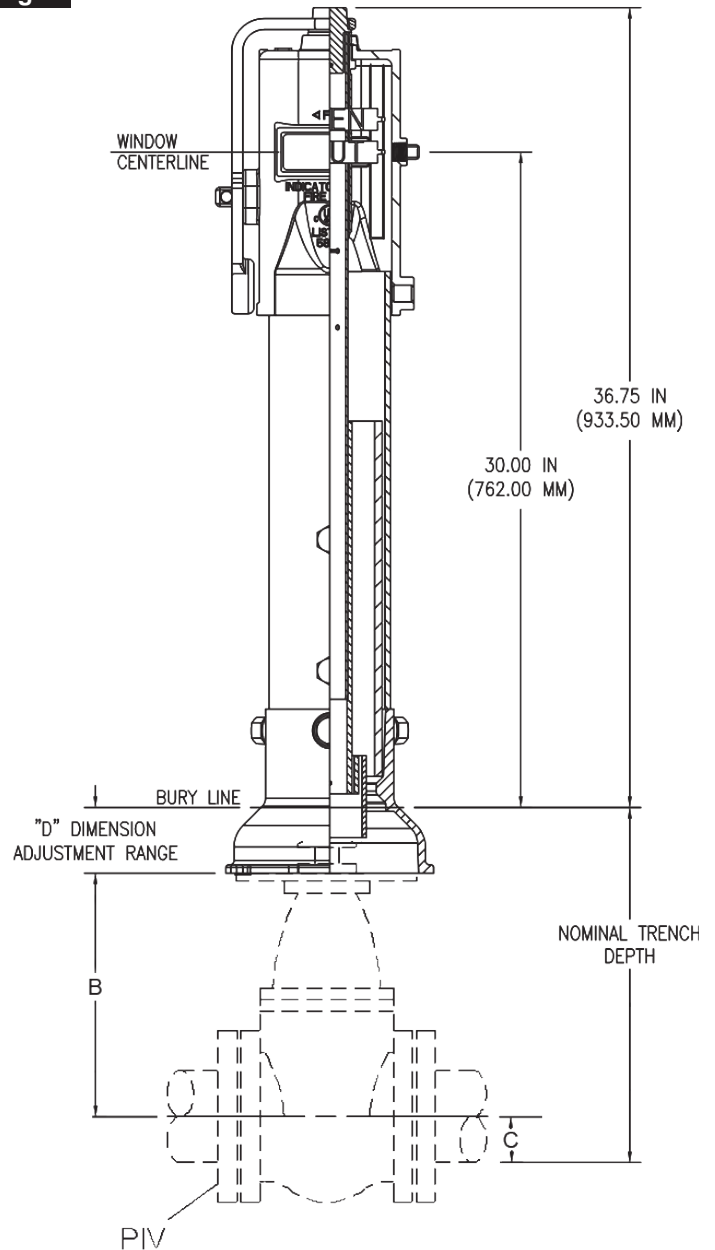

# U.S. PIPE VALVE & HYDRANT, LLC

## U-20806/U-20807 SHALLOW BURY ADJUSTABLE VERTICAL INDICATOR POST

### INSTALLATION INSTRUCTIONS

**Table 1** Dimension 'B'

for U.S. Pipe Valve & Hydrant, LLC Resilient Wedge Post Indicator Valves

Valve Size	Dimensions in Inches	Turns To Open
	B	
4"	10.95	14
6"	14.91	20-1/2
8"	18.02	26-1/2
10"	21.62	33
12"	24.52	38-1/2
14"	29.13	43-1/2
16"	32.35	49
18"	38.35	57
20"	41.48	63
24"	47.94	75

**Table 2** Dimension 'C' - 1/2 of Pipe O.D.

(Typical for underground pipe)

Pipe Size	Dimension 'C' in Inches
4"	2.40
6"	3.45
8"	4.53
10"	5.55
12"	6.60
14"	7.65
16"	8.70
18"	9.75
20"	10.80
24"	12.90

**Table 3** Dimension 'D' Adjustment Range

Minimum	Maximum
3"	14"

**Table 4a** Nominal Trench Depths

for U.S. Pipe Valve & Hydrant, LLC U-20806 Resilient Wedge Post Indicator Valves

Order Length S			
Part Number	Valve size	Minimum	Maximum
U-20806	4"	1' - 4"	2' - 3"
	6"	1' - 9"	2' - 8"
	8"	2' - 1"	3" - 0"
	10"	2' - 6"	3" - 5"
	12"	2' - 10"	3" - 9"
	14"	3" - 4"	4' - 3"

**Table 4b** Nominal Trench Depths

for U.S. Pipe Valve & Hydrant, LLC U-20807 Resilient Wedge Post Indicator Valves

Order Length S			
Part Number	Valve size	Minimum	Maximum
U-20807	16"	3' - 8"	4' - 7"
	18"	4' - 3"	5' - 2"
	20"	4' - 7"	5' - 6"
	24"	5' - 4"	6' - 3"

# U.S. PIPE VALVE & HYDRANT, LLC U-20806/U-20807 SHALLOW BURY ADJUSTABLE VERTICAL INDICATOR POST

## INSTALLATION INSTRUCTIONS

### Supervisory Control Valve Switch:

Figures E and F illustrate attachment of the Supervisory Control Valve Switch (supplied by customer).

### INSTALLATION

Post Targets must be positioned for use with the appropriate number of turns to open the post indicator valve. Improper positioning of the Targets can result in an erroneous indication of the open or shut position of the valve. The U-20806 Indicator Post will accommodate positioning of the Targets to operate PIVs requiring 14 to 43 turns to open; the U-20807 Indicator Post will accommodate positioning the Targets to operate PIVs requiring 49 to 75 turns to open.

### NOTE

*The Targets for the U-20806 Indicator Post have been factory set for use with a 6 inch U.S. Pipe Valve & Hydrant, LLC PIV and the Targets for the U-20807 Indicator Post have been factory set for a 24 inch U.S. Pipe Valve & Hydrant, LLC PIV. Consequently, Steps 6 through 10 need not be performed when installing the U-20806 Post with a 6 inch U.S. Pipe Valve & Hydrant, LLC PIV (or with a PIV that requires 20-1/2 turns to open) or the U-20807 Post with a 24 inch U.S. Pipe Valve & Hydrant, LLC PIV (or with a PIV that requires 75 turns to open).*

### Proceed to install the Post as follows:

1. Completely close the PIV.
2. Place approximately 5 inch high blocks onto the stuffing box flange of the installed valve. Set the Indicator Post onto the blocks and generally centered over the PIV operating nut.
3. Slide out the Shipping Disk, and allow the Coupling (5b) to drop down over the PIV operating nut. Attach the Coupling to the operating nut with the Cotter Pin (5d).
4. Remove the blocks and lower the Indicator Post onto the PIV stuffing box flange. Bolt the Bell and stuffing box flange together using the four Cap Screws and Nuts (17, 18). Also at this time make certain that the three Cap Screws (6) securing the Bell (4) to the Lower Barrel (3) are uniformly tightened.

**Fig. C**

1. Post Head
2. Upper Barrel
3. Lower Barrel
4. Bell
5. Lower Stem Assembly
  - a. Lower Stem
  - b. Coupling
  - c. Coupling insert
  - d. Cotter Pin, 1/4" x 3" (2 req'd)
6. Hex Head Cap Screw 3/4-10UNC x 1" (5 req'd)
7. Hex Socket Set Screw 3/4-10UNC x 1" (5 req'd)
8. Pipe Plug, 1/2" NPT
9. Window (2 req'd)
11. Wrench
12. Upper Stem Assembly
  - a. Operating Nut
  - b. Spring Pin, 1/8" x 2-1/4"
  - c. Cotter Pin, 1/8" x 1-1/2"
  - d. Threaded sleeve
  - e. Upper Stem
13. Weather Cap
14. Retaining Ring
15. "OPEN" Target
16. "SHUT" Target
17. Hex Head Cap Screw, 5/8-11UNC x 2-1/4 (4 req'd)
18. Hex Nut, 5/8-11UNC (4 req'd)

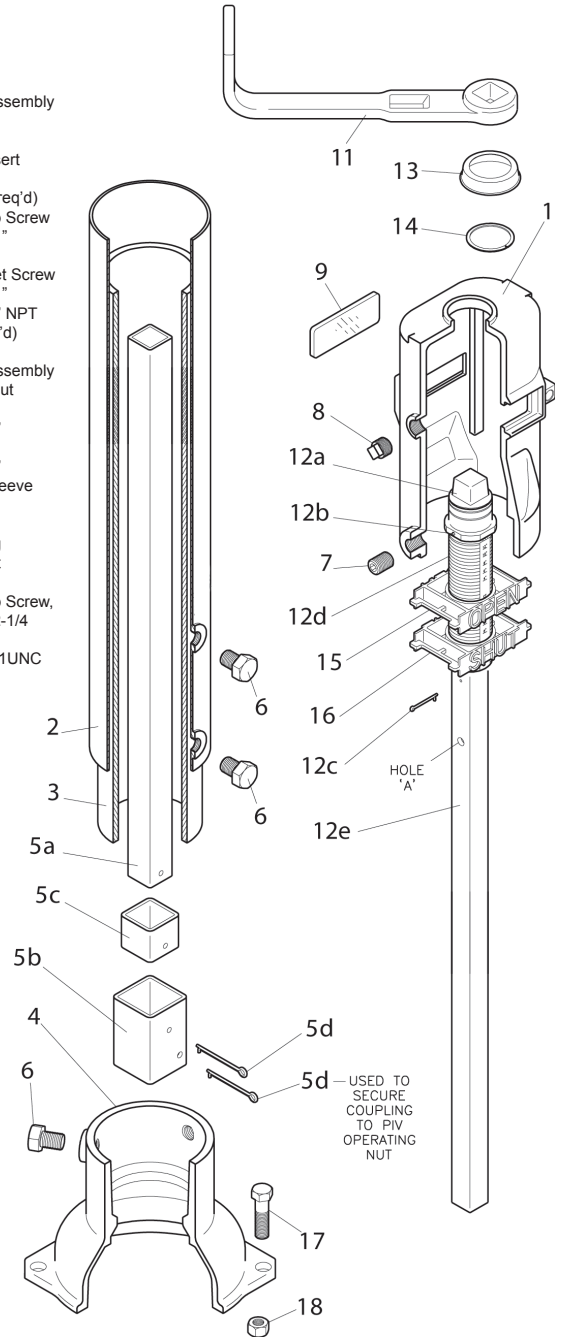

**MODEL U-20806/U-20807  
VERTICAL INDIATOR POST ASSEMBLY**

# U.S. PIPE VALVE & HYDRANT, LLC

## U-20806/U-20807 SHALLOW BURY ADJUSTABLE VERTICAL INDICATOR POST

### INSTALLATION INSTRUCTIONS

#### NOTES

If the pipe is sloped, it may be necessary to shim some of the Cap Screws (17) with steel washers, so that the Post will be plumb and the Stem will run true with the center of the Post Head. Coupling clearances can accommodate a maximum pipe slope of 5 degrees.

It is recommended that a spirit level be used to set the vertical alignment of the Indicator Post.

5. Loosen the Set Screw (7), and lift the Post Head/Upper Stem Assembly (1, 12) just high enough to insert a philips head screwdriver through Hole "A" in the Upper Stem (12e). The philips head screwdriver will temporarily hold the Post Head (1) above the upper Barrel (2).

6. Remove the Wrench (11), pry off the Cap (13), remove the Retaining Ring (14), and then lift the Post Head clear of the Upper Stem Assembly (12).

7. Position the Targets per Figure D.

8. Replace the Post Head (1), Retaining Ring (14), and Cap (13).

9. Remove the phillips head screwdriver, lower the Post Head, and tighten the Set Screw (7).

10. Using the Wrench (11), open and close the valve and check to see that the "SHUT" and "OPEN" Targets are clearly in view in the Windows, at their respective positions, and that there is no feeling of binding of the Upper or Lower Stem Assemblies (5, 12). It is recommended that the turns to open/close be counted and compared to the valve manufacturer's specification, in order to verify full valve opening.

#### NOTES

If there is any indication of binding of the internal operating parts, the vertical alignment of the Indicator Post must be corrected.

If the Target Plates are not properly in view, completely close the PIV and then repeat Steps 6 through 11.

11. Loosen the two Cap Screws (6) at the base of the Upper Barrel (2) and then slide the Post Head up until the Bury Line of the Post Head coincides with the planned finished grade. Tighten the two Set Screws (6) at the base of the Post Head with a torque of 40 to 60 ft.lbs. When properly installed, the centerline of the Target Windows will be 30 inches above the finish grade.

**Fig. D**

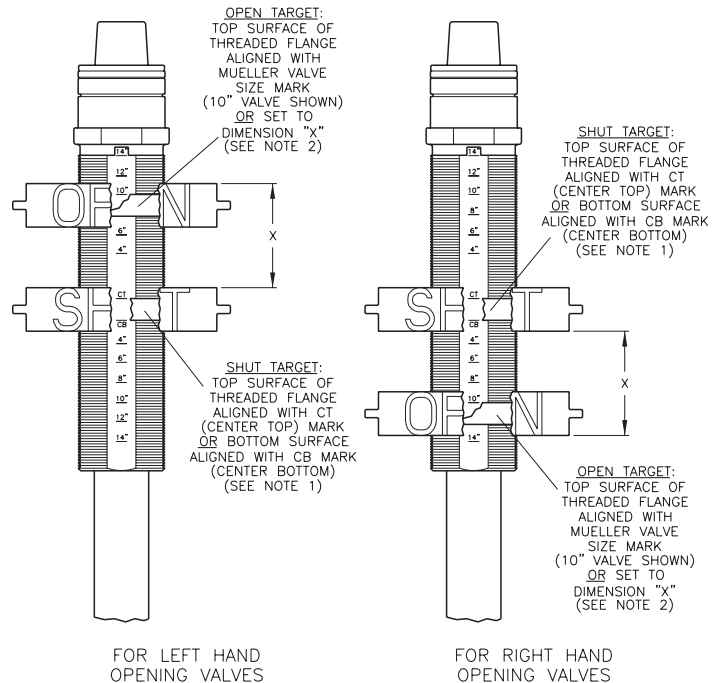

#### U-20806 INDICATOR POST

##### NOTES

1. SET SHUT TARGET FIRST.
2. FOR VALVES MANUFACTURED BY OTHER THAN U.S. PIPE VALVE & HYDRANT, LLC COMPANY, SET TO DIMENSION 'X' CALCULATED AS FOLLOWS:

$$'X' \text{ IN INCHES} = \frac{\text{NO. OF TURNS TO OPEN VALVE}}{14}$$

#### U-20807 INDICATOR POST

##### NOTES

1. SET SHUT TARGET FIRST.
2. FOR VALVES MANUFACTURED BY OTHER THAN U.S. PIPE VALVE & HYDRANT, LLC COMPANY, SET TO DIMENSION 'X' CALCULATED AS FOLLOWS:

$$'X' \text{ IN INCHES} = \frac{\text{NO. OF TURNS TO OPEN VALVE}}{22}$$

#### POSITIONING OF TARGETS

12. Back-fill to final grade and repeat Step 11.

13. Tighten the switch mounting hole plug if the Supervisory Control Valve Switch is not to be immediately attached.

14. Proceed to install the Supervisory Control Valve Switch (supplied by customer) - continued on next page.

15. Remove the Cover from the assembly, and then loosen the Trip Rod Locking Screw. Adjust the position of the Trip Rod so that it extends about 1-3/8 inches beyond the Nipple, and then securely tighten the Trip Rod Locking Screw.

# U.S. PIPE VALVE & HYDRANT, LLC

## U-20806/U-20807 SHALLOW BURY

### ADJUSTABLE VERTICAL INDICATOR POST

#### INSTALLATION INSTRUCTIONS

**15a.** Rotate the Post Operating Nut until the PIV is fully open. Note the position of one of the “OPEN” Targets in its Window.

**15b.** Rotate the Operating Stem until the “OPEN” Targets are out of the Post Windows. Note the direction in which the “OPEN” Target will move when it is returned to the Post Window.

**15c.** Remove the Nipple from the assembly, and then with the Locknut screwed over the Nipple threads, hand tighten the Nipple into the 1/2 inch NPT hole provided in the Post Head, and then tighten the Locknut against the Post Head to secure the Nipple firmly in place.

**15d.** Refer to Figure E or F as appropriate, and note the direction in which the Trip Rod must move when the “OPEN” Target is returned to the Post Window.

Slide the assembly as far as possible onto the Nipple while maintaining proper orientation of the assembly, and then tighten the Set Screw that holds the assembly onto the Nipple.

**15e.** Attach leads from an electrical continuity meter to the appropriate terminals.

**15f.** Return the valve to its fully open position. Verify that the “OPEN” Target returns to the position noted in Step b. Also, verify that the Switch contacts change position within two turns of the valve being fully open.

**15g.** Begin to return the valve to its closed position. Verify that the Switch contacts change back to their original position within two turns from full open.

#### NOTE

*If the Upper Stem Assembly binds before the “OPEN” Target reaches its full open position, or the switch contacts do not change position as described in Steps g and h, then the Targets must be readjusted.*

*If the Targets require readjustment, close the PIV, remove the Switch assembly, and repeat Steps 6 and 11; however, when positioning the Targets, rotate both Targets at the same time as necessary so that the “OPEN” target will trip the Actuator Rod of the Switch. Repositioning of the “OPEN” and “SHUT” Targets relative to each other should not be necessary. Repeat Steps b through h.*

**15h.** Remove the electrical continuity test leads. The external field wiring connections can now be made to the Switch.

**Fig. E**

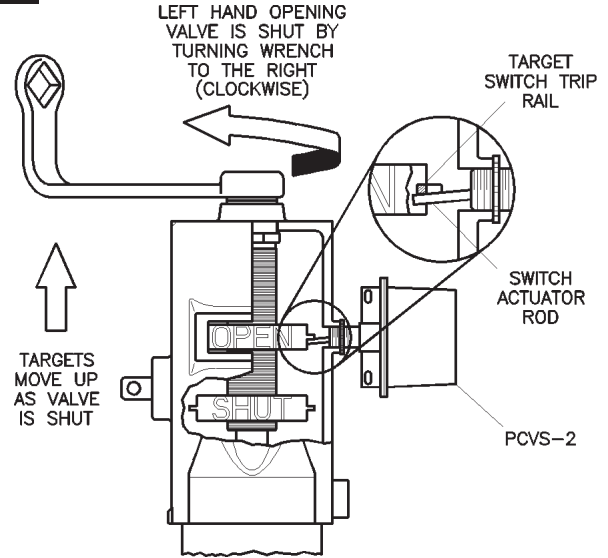

**ATTACHMENT OF THE SUPERVISORY CONTROL VALVE SWITCH FOR LEFT HAND OPENING VALVES**

**Fig. F**

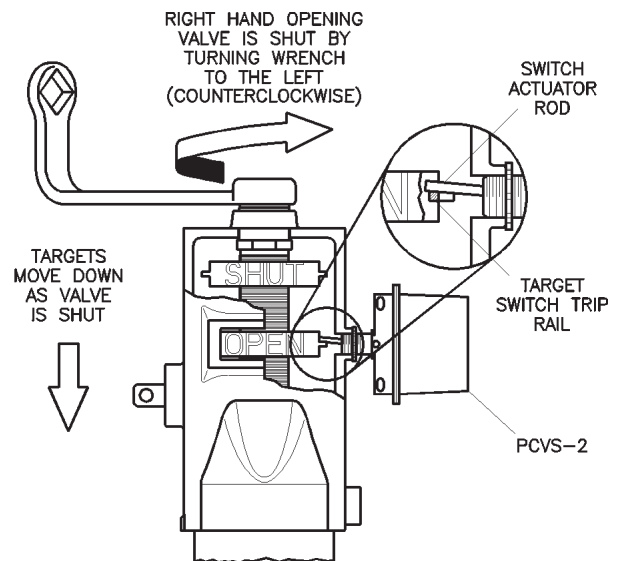

**ATTACHMENT OF THE SUPERVISORY CONTROL VALVE SWITCH FOR RIGHT HAND OPENING VALVES**

#### NOTE

*Use of a weathertight conduit connector with a gasket seal is recommended.*

# U.S. PIPE VALVE & HYDRANT, LLC

## U-20806/U-20807 SHALLOW BURY

### ADJUSTABLE VERTICAL INDICATOR POST

#### INSTALLATION INSTRUCTIONS

#### CARE AND MAINTENANCE

Model U-20806/U-20807 Indicator Posts do not require any regular schedule maintenance.

It is recommended that Indicator Posts used to operate fire protection system water control valves be locked in the fully-open position using the Post Wrench as shown in Figure A. The locks must be sturdy and resistant to breakage except by heavy bolt cutters.

It is also recommended that once a month a visual inspection procedure be followed, with the following items checked:

1. The Post Head, Upper Barrel, and Windows have not been damaged.
2. The Targets indicate that the valve is open.
3. The Wrench is in place on the Indicator Post, and it is properly locked open.

In addition, on a quarterly basis, the Indicator Post should be closed two turns and then reopened tight to verify that the PIV is in the full open position and properly engages with the Post and, that the Supervisory Switch contacts (if applicable) properly change position.

Any damaged parts must be immediately replaced. The Indicator Post should also be physically tried to be sure that the valve is in the fully-open position, if there are any damaged parts, sign of tampering, or the position of the valve is questionable.

#### NOTES

*Before closing a fire protection system main valve for maintenance work on either the Indicator Post or fire protection systems which it controls, permission to shut down the affected fire protection systems must first be obtained from the proper authorities and all personnel who may be affected by this decision must be notified.*

It is recommended that fire protection systems be inspected by a qualified Inspection Service.

#### REPLACEMENT PARTS:

Specify: (specify description) for use with Model U-20806/U-20807 Indicator Post, Part No. (specify).

- |  |          |
|--|----------|
| 1. O.L. Post Head (U-20806).....               | 148692   |
| 1. O.R. Post Head (U-20806).....               | 148649   |
| 1. O.L. Post Head (U-20807).....               | 241029   |
| 1. O.R. Post Head (U-20807).....               | 241030   |
| 2. Upper Barrel "S".....                       | 241261   |
| 3. Lower Barrel "S" PVC.....                   | 241259   |
| 3. Lower Barrel "S" DI.....                    | 241262   |
| 4. Bell.....                                   | 148689   |
| 5a. Lower Stem Assembly "S".....               | 287857   |
| 5b. Coupling.....                              | 290155   |
| 5c. Coupling Insert.....                       | 290156   |
| 5d. Long Cotter Pin.....                       | 290154   |
| 6. Hex Head Cap Screw, 3/4 - 10 UNC x 1".....  | 190560   |
| 7. Hex Socket Set Screw 3/4 - 10 UNC x 1"..... | 198428   |
| 8. Pipe Plug 1/2" NPT.....                     | 198582   |
| 9. Window.....                                 | 148790   |
| 11. Wrench (U-20806).....                      | 148690-1 |
| 11. Wrench (U-20807).....                      | 241013   |
| 12. Upper Stem Assembly (U-20806).....         | 287855   |
| 12. Upper Stem Assembly (U-20807).....         | 287859   |
| 12a. A Square Op Nut.....Right                 | 14969-1  |
| 12a. A Square Op Nut.....Left                  | 148691   |
| 12b. Springpin.....                            | 190330   |
| 12c. Short Cotter Pin.....                     | 290158   |
| 12d. Threaded Sleeve (U-20806).....            | 148634   |
| 12d. Threaded Sleeve (U-20807).....            | 241011   |
| 12e. Upperstem.....                            | 241260   |
| 13. Weather Cap.....                           | 290143   |
| 14. Retaining Ring.....                        | 290157   |
| 15. Target Open (U-20806).....                 | 290144   |
| 15. Target Open (U-20807).....                 | 290552   |
| 16. Target Shut (U-20806).....                 | 290145   |
| 16. Target Shut (U-20807).....                 | 290553   |
| 17. Hex Bolt.....                              | 290191   |
| 18. Hex Nut.....                               | 190939   |

NOTE: For models with handwheels, contact customer service for replacement parts.

# U.S. PIPE VALVE & HYDRANT, LLC U-20806/U-20807 SHALLOW BURY ADJUSTABLE VERTICAL INDICATOR POST

INSTALLATION INSTRUCTIONS

---



**VALVE &  
HYDRANT**

## U.S. Pipe Valve & Hydrant, LLC

500 Eldorado St.  
Decatur, IL 62522  
[www.uspvh.com](http://www.uspvh.com)

Phone: 217.425.2194  
Toll Free: 1.800.871.2194  
[support@uspvh.com](mailto:support@uspvh.com)

Copyright © 2016 U.S. Pipe Valve & Hydrant, LLC. All Rights Reserved.

The trademarks, logos and service marks displayed in this document herein are the property of U.S. Pipe Valve & Hydrant, LLC, its affiliates or other third parties. Products above marked with a section symbol (§) are subject to patents or patent applications. For details, visit [www.mwppat.com](http://www.mwppat.com). These products are intended for use in potable water applications. Please contact your U.S. Pipe Valve & Hydrant Sales or Customer Service Representative concerning any other application(s).

**Form 12970USPVH - Rev 3/16**